

Product specifications

V4 SERIES DEMAND CONTROL
KITCHEN VENTILATION SYSTEM

ecoAzur[®]

intellinox



INDEX

ABBREVIATIONS	4
ECOAZUR® OVERVIEW	5
ECOAZUR® AGENCY LISTING	6
 PROCESSOR PANELS	
V4PPLTE1	7
V4PP04STD1	9
V4PP08STD1	11
V4PP04PLUS1	13
V4PP08PLUS1	15
V4PP12PLUS1	17
V4PP16PLUS1	19
V4PP20PLUS1	21
 CONTROLLERS	
V4CU1	23
V4TC1	25
V4NE1	27
V4NE2	29
 USER INTERFACE	
V4CT1E	31
 SENSORS	
V4TT2	33
V4IB1	35
V4AS1	37
V4DS1	38
V4TT3	39
 CABLES	
V4NF series	40
 MODULATING DAMPERS	
V4MD2	41
V4MD-R, V4MD-C	43
 PRESSURE CONTROL	
V4MD-PT5	45

ABBREVIATIONS

BAS – Building Automation System

DCKV – Demand Control Kitchen Ventilation

ECM – Electronically Commutated Motor

KEF – Kitchen Exhaust Fan

MUA – Make-up Air Unit

VFD – Variable Frequency Drives

ECOAZUR[®] TERMINOLOGY

AS – Analog input module

CT – Keypad (user interface)

CU – Processor Unit

DS – Digital input module

IB – Optic sensor

MD – Modulating damper

NE – Hood sensor network hub

NF – Network cable

PT – Pressure transmitter

TC – Output module

TT – Temperature transmitter

ECOAZUR® OVERVIEW

In commercial kitchens, exhaust and supply fans are running continuously throughout the day – even when little to no cooking is taking place. Demand Control Kitchen Ventilation (DCKV) systems will automatically control the speed of these units by measuring the level of cooking activity.

The ECOAZUR® DCKV control system brings energy savings to commercial kitchen’s electric, heating and cooling usage without compromising the comfort of the kitchen staff. In order to achieve this, the ECOAZUR® uses real-time detection of particulate and temperature changes to adjust kitchen fan speeds when and where needed. ECOAZUR® uses optic sensors, temperature sensors, and optional modulating dampers to ensure the highest amount of savings. This results in a clean, comfortable kitchen while generating substantial energy savings.

The ECOAZUR® control system adapts to any hood, in new or retrofit commercial kitchens. Its proprietary communication protocols offers a versatile sensor network topology:

- Automatic detection/addressing of ECOAZUR® intelligent sensors
- User-friendly RJ45 connections limit wiring errors
- ECOAZUR® network hubs minimize cable lengths

The hood sensor network components may include:

- Optic sensors (IB) – located in the hood canopy
- Temperature sensors (TT) – located in the hood canopy and/or the hood collars
- Pressure sensors (PT) – located in the exhaust ducts and/or behind the hood plenum
- Network hubs (NE) – located above the hood
- User interface (CT) – one or many keypads may be installed throughout the kitchen
- Digital input modules (DS) – panel mount, signal coming from a third-party device
- Analog input modules (AS) – panel mount, signal coming from a third-party device
- Network cables (NF) – designed specifically for the hood environment, RJ45 connectors

The Processor Panel components include:

- ECOAZUR® Processor (CU)
- ECOAZUR® Output Module(s) (TC)
- Power Supply (120-220Vac to 24Vdc)
- Light Control Relay
- Cloud Module (optional)

The ECOAZUR® Processor Panel interfaces to ventilation equipment and third-party devices such as:

- VFDs, ECMs and/or ECOAZUR® Modulating Dampers
- Fire Suppression System
- Hood Lights
- BAS inputs/outputs
- Kitchen temperature sensor (optional)

Processor Panel Selection	Maximum Hood Sensor Network Size	Ventilation equipment / Output Channels	Modulating Dampers	Hood Light Control (max. load)	Enclosure UL Type	ECOAZUR® Cloud Option
ECOAZUR® Lite	75 devices	4	No	6A	1	Supported
ECOAZUR® Standard	75 devices	4, 8	No	12A	4	Supported
ECOAZUR® Plus	75 devices	4, 8, 12, 16, 20	Yes	12A	4	Supported

ECOAZUR[®] AGENCY LISTING

Conforms to the following ANSI/UL Standards (cETLus):

- UL 2017 – Standard for General-Purpose Signaling Devices and Systems
- UL 508A – Standard for Industrial Control Panels
- NSF-2 – Standard for Food Service Equipment

Certified to the following CAN/CSA Standards (cETL):

- C22.2 No. 205 – Signal Equipment
- C22.2 No. 14 – Industrial Control Panels

Official Intertek laboratory tests reports support that the ECOAZUR[®] system has been evaluated and found to comply with the component requirements for:

- UL 1978 Standard for Safety Grease Ducts
- UL 710 Exhaust Hoods for Commercial Cooking Equipment
- ULC S646 Standard for Exhaust Hoods and Related Controls for Commercial and Institutional Kitchens.

Official EMC laboratory test reports support compliance with:

- Electromagnetic compatibility directive 2014/30/EU as part of the requirements leading to the CE marking of ECOAZUR[®] system. Harmonized standards: EN61000-6-4 (2007) A1 (2011), EN61000-6-2 (2005)
- FCC part 15 subpart B
- ICES-003

Compliance is valid with the following provisions:

- The product specifications, electrical diagrams and installation instructions are followed.
- Only ECOAZUR[®] V4NF series network cables are used for the hood sensor network.
- Only Delta power supplies M/N DRP024V060W1NZ are used to power ECOAZUR[®] low voltage components.

V4PPLTE1

ECOAZUR® Lite Processor Panel, 4 Output Channels

PROCESSOR PANELS

Functional Description



The ECOAZUR® DCKV is a modular system designed to match complex kitchen ventilation applications as well as simple installations. The V4PPLTE1 entry-level processor panel may host up to 75 ECOAZUR® intelligent hood sensors, sensor hubs and keypads while controlling a combined total of 4 exhaust and supply fans. The ECOAZUR® Lite series differs from the Standard series mainly by its compact UL type 1 enclosure.

- Controls hood ventilation and hood lights automatically
- Does not support modulating dampers (MDs)
- Not limited to any VFD models as hardwired points are used to control equipment
- Located in the kitchen above the ceiling or in the electrical room
- Includes one (1) V4CU1 and one (1) V4TC1.

Specifications

Electrical Rating	Input 1	Terminals L-N Function: DCKV controls (use a dedicated branch circuit) 120-220 VAC / 1 PH / 50-60HZ, 0.5A – 0.3A 12-14AWG, 7.1 lb-in (0.8Nm), Stripping length: 3/8" (9.5mm)
	Input 2	Terminals HL1-HL2 Function: Hood lights (use a dedicated branch circuit) 120-220 VAC / 1PH / 50-60HZ, 6A (maximum load) 12-14AWG, 7.1 lb-in (0.8Nm), Stripping length: 3/8" (9.5mm)
	Output 1	Terminals HL3-HL4 Function: Hood lights 120-220 VAC / 1PH / 50-60HZ, 6A (maximum load) 12-14AWG, 7.1 lb-in (0.8Nm), Stripping length: 3/8" (9.5mm)
Low Voltage Connections	Wiring Terminals	16 to 18AWG, Copper conductors only, Stranded or solid core, 75degC Stripping length: 0.25" (6mm) Tightening Torque: 3.5lb-in (0.5Nm) Field wiring: Class 2 circuits. Use shielded 75degC Plenum rated cables.
	5 Digital Inputs	CU processor configurable digital inputs (DI1...DI5), 24VDC DI1: Hood Fire Suppression System Interlock to ECOAZUR® N.C. contact. Wire in series when more than one system.
	3 Digital Outputs	CU processor configurable digital outputs (DO1...DO3) Solid State Relay (24V AC/DC, 100mA max.)
	Hood Sensor Network	CU processor RJ45 communication input ports (CI1...CI6) Individually fused (non-replaceable). Connects to ECOAZUR® sensors, keypads and hubs. <u>Use V4NF series cables only.</u> Each port provides diagnostic indicators <ul style="list-style-type: none"> - Green LED: 24V status - Orange LED: communication status Ports are universal, except when connected to V4IB1 optic sensors: <ul style="list-style-type: none"> - CI1 & CI2 form a first optic sensor pair - CI3 & CI4 form a second optic sensor pair - Both optic sensor pairs may be in line of sight with each other and do not interfere with one another.
	4 Output Channels	Configurable output channels (DO1-AO1...DO4-AO4). Used to control equipment such as VFDs, ECMs, MD dampers or BAS signals. AO1...AO4: Analog Output, 0-10V (configurable, 4-point characterization) DO1...DO4: Digital Output, Solid State Relay (24V AC/DC, 100mA max.)*

**DO1 is equipped with an interposing relay to interlock a make-up air control logic (24-220V, 6A max. load) (N.O. contact wired to" M1-1" & "M1-2")*

Ambient Limits	Temperature: 41 to 131 deg F (5 to 55 deg C) Humidity: 10% to 90% RH non-condensing, indoor location
Enclosure material	Painted Steel
Enclosure type	1 (locate enclosure in the kitchen <u>above the ceiling</u> or in the electrical room)
Weight	16.4 lb (7.4 kg)

Agency Listing



- Conforms to ANSI/UL Standard 508A, Industrial Control panels.
- Certified to CAN/CSA Standard C22.2 No. 14, Industrial Control Equipment
- Conforms to ANSI/UL Standard 2017, Safety General-Purpose Signaling Devices and Systems.
- Certified to CAN/CSA Standard C22.2 No. 205, Signal Equipment

Dimensions

Height (H)	12" (305 mm)
Width (W)	12" (305 mm)
Depth (D)	6" (152 mm)



V4PPLTE1

Processor Panel

(removable 1/2" and 3/4" knockouts on all four sides)

Maintenance

- No maintenance required.

V4PP04STD1

ECOAZUR® Standard Processor Panel, 4 Output Channels

PROCESSOR PANELS

Functional Description



The ECOAZUR® DCKV is a modular system designed to match complex kitchen ventilation applications as well as simple installations. The V4PP04STD1 processor panel may host up to 75 ECOAZUR® intelligent hood sensors, sensor hubs and keypads while controlling a combined total of 4 exhaust and supply fans. No MD dampers are supported with the Standard series.

- Controls hood ventilation and hood lights automatically
- Not limited to any VFD models as hardwired points are used to control equipment
- Typically located in the kitchen above the ceiling or in the electrical room
- Includes one (1) V4CU1 and one (1) V4TC1

Specifications

Electrical Rating	Input 1	Terminals L-N Function: DCKV controls (use a dedicated branch circuit) 120-220 VAC / 1 PH / 50-60HZ, 0.5A 12-14AWG, 7.1 lb-in (0.8Nm), Stripping length: 3/8" (9.5mm)
	Input 2	Terminals HL1-HL2 Function: Hood lights (use a dedicated branch circuit) 120-220 VAC / 1PH / 50-60HZ, 12A (maximum load) 12-14AWG, 7.1 lb-in (0.8Nm), Stripping length: 3/8" (9.5mm)
	Output 1	Terminals HL3-HL4 Function: Hood lights 120-220 VAC / 1PH / 50-60HZ, 12A (maximum load) 12-14AWG, 7.1 lb-in (0.8Nm), Stripping length: 3/8" (9.5mm)
Low Voltage Connections	Wiring Terminals	16 to 18AWG, Copper conductors only, Stranded or solid core, 75degC Stripping length: 0.25" (6mm) Tightening Torque: 3.5lb-in (0.5Nm) Field wiring: Class 2 circuits. Use shielded 75degC Plenum rated cables.
	FA1-FA2	Hood Fire Suppression System Interlock to ECOAZUR® N.C. contact. Wire in series when more than one system.
	5 Digital Inputs	CU processor configurable digital inputs (DI1...DI5) 24VDC
	3 Digital Outputs	CU processor configurable digital outputs (DO1...DO3) Solid State Relay (24V AC/DC, 100mA max.)
	Hood Sensor	CU processor RJ45 communication input ports (CI1...CI6) Individually fused (non-replaceable).
	Network	Connects to ECOAZUR® sensors, keypads and hubs. <u>Use V4NF series cables only.</u> Each port provides diagnostic indicators <ul style="list-style-type: none"> - Green LED: 24V status - Orange LED: communication status Ports are universal, except when connected to V4IB1 optic sensors: <ul style="list-style-type: none"> - CI1 & CI2 form a first optic sensor pair - CI3 & CI4 form a second optic sensor pair - Both optic sensor pairs may be in line of sight with each other and do not interfere with one another.
4 Output Channels	Configurable output channels (DO1-AO1...DO4-AO4). Used to control equipment such as VFDs, ECMs, MD dampers or BAS signals. AO1...AO4: Analog Output, 0-10V (configurable, 4-point characterization) DO1...DO4: Digital Output, Solid State Relay (24V AC/DC, 100mA max.)*	

**DO1 is equipped with an interposing relay to interlock a make-up air control logic (24-220V, 6A max. load) (N.O. contact wired to "M1-1" & "M1-2")*

Ambient Limits	Temperature: 41 to 131 deg F (5 to 55 deg C) Indoor location
Enclosure material	Painted Steel
Enclosure type	4
Weight	26.6 lb (12.1 kg)

Agency Listing



- Conforms to ANSI/UL Standard 508A, Industrial Control panels.
- Certified to CAN/CSA Standard C22.2 No. 14, Industrial Control Equipment
- Conforms to ANSI/UL Standard 2017, Safety General-Purpose Signaling Devices and Systems.
- Certified to CAN/CSA Standard C22.2 No. 205, Signal Equipment

Dimensions

Height (H) 16" (406 mm)
Width (W) 14" (356 mm)
Depth (D) 6" (152mm)



V4PP04STD1
Processor Panel
(No openings)

Maintenance

- No maintenance required.

V4PP08STD1

ECOAZUR® Standard Processor Panel, 8 Output Channels

PROCESSOR PANELS

Functional Description



The ECOAZUR® DCKV is a modular system designed to match complex kitchen ventilation applications as well as simple installations. The V4PP08STD1 processor panel may host up to 75 ECOAZUR® intelligent hood sensors, sensor hubs and keypads while controlling a combined total of 8 exhaust and supply fans. No MD dampers are supported with the Standard series.

- Controls hood ventilation and hood lights automatically
- Not limited to any VFD models as hardwired points are used to control equipment
- Typically located in the kitchen above the ceiling or in the electrical room
- Includes one (1) V4CU1 and two (2) V4TC1

Specifications

Electrical Rating	Input 1	Terminals L-N Function: DCKV controls (use a dedicated branch circuit) 120-220 VAC / 1 PH / 50-60HZ, 0.5A – 0.3A 12-14AWG, 7.1 lb-in (0.8Nm), Stripping length: 3/8" (9.5mm)
	Input 2	Terminals HL1-HL2 Function: Hood lights (use a dedicated branch circuit) 120-220 VAC / 1PH / 50-60HZ, 12A (maximum load) 12-14AWG, 7.1 lb-in (0.8Nm), Stripping length: 3/8" (9.5mm)
	Output 1	Terminals HL3-HL4 Function: Hood lights 120-220 VAC / 1PH / 50-60HZ, 12A (maximum load) 12-14AWG, 7.1 lb-in (0.8Nm), Stripping length: 3/8" (9.5mm)
Low Voltage Connections	Wiring Terminals	16 to 18AWG, Copper conductors only, Stranded or solid core, 75degC Stripping length: 0.25" (6mm) Tightening Torque: 3.5lb-in (0.5Nm) Field wiring: Class 2 circuits. Use shielded 75degC Plenum rated cables.
	FA1-FA2	Hood Fire Suppression System Interlock to ECOAZUR® N.C. contact. Wire in series when more than one system.
	5 Digital Inputs	CU processor configurable digital inputs (DI1...DI5) 24VDC
	3 Digital Outputs	CU processor configurable digital outputs (DO1...DO3) Solid State Relay (24V AC/DC, 100mA max.)
	Hood Sensor	CU processor RJ45 communication input ports (CI1...CI6) Individually fused (non-replaceable).
	Network	Connects to ECOAZUR® sensors, keypads and hubs. <u>Use V4NF series cables only.</u> Each port provides diagnostic indicators <ul style="list-style-type: none"> - Green LED: 24V status - Orange LED: communication status Ports are universal, except when connected to V4IB1 optic sensors: <ul style="list-style-type: none"> - CI1 & CI2 form a first optic sensor pair - CI3 & CI4 form a second optic sensor pair - Both optic sensor pairs may be in line of sight with each other and do not interfere with one another.
	8 Output Channels	Configurable output channels (DO1-AO1...DO8-AO8). Used to control equipment such as VFDs, ECMs, MD dampers or BAS signals. AO1...AO8: Analog Output, 0-10V (configurable, 4-point characterization) DO1...DO8: Digital Output, Solid State Relay (24V AC/DC, 100mA max.)*

**DO1 is equipped with and interposing relay to interlock a make-up air control logic (24-220V, 6A max. load) (N.O. contact wired to "M1-1" & "M1-2"*

Ambient Limits	Temperature: 41 to 131 deg F (5 to 55 deg C) Indoor location
Enclosure material	Painted Steel
Enclosure type	4
Weight	34.0 lb (15.4 kg)

Agency Listing



- Conforms to ANSI/UL Standard 508A, Industrial Control panels.
- Certified to CAN/CSA Standard C22.2 No. 14, Industrial Control Equipment
- Conforms to ANSI/UL Standard 2017, Safety General-Purpose Signaling Devices and Systems.
- Certified to CAN/CSA Standard C22.2 No. 205, Signal Equipment

Dimensions

Height (H)	20" (508 mm)
Width (W)	16" (406 mm)
Depth (D)	6" (152mm)

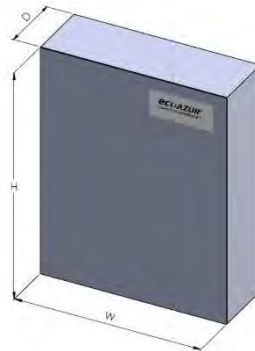

V4PP08STD1
Processor Panel
(No openings)

Maintenance

- No maintenance required.

V4PP04PLUS1

ECOAZUR® Plus Processor Panel, 4 Output Channels

PROCESSOR PANELS

Functional Description



The ECOAZUR® DCKV is a modular system designed to match complex kitchen ventilation applications as well as simple installations. The V4PP04PLUS1 processor panel may host up to 75 ECOAZUR® intelligent hood sensors, sensor hubs and keypads while controlling a combined total of 4 exhaust/supply fans and modulating dampers (MD).

- Controls hood ventilation and hood lights automatically
- Controls the main exhaust duct static pressure
- Designed to work with ABB ACH550/ACS320 VFDs and V4MD2 fast-running damper actuators
- Includes one (1) V4CU1, one (1) V4TC1 and 24V supply for 4 MD actuators
- Should the hood fire suppression system be released or a VFD be on BYPASS, all modulating dampers are interlocked to a fail-safe open position within 4 seconds
- Typically located in the kitchen above the ceiling or in the electrical room

Specifications

Electrical Rating	Input 1	Terminals L-N Function: DCKV controls (use a dedicated branch circuit) 120-220 VAC / 1 PH / 50-60HZ, 1.3-0.7A 12-14AWG, 7.1 lb-in (0.8Nm), Stripping length: 3/8" (9.5mm)
	Input 2	Terminals HL1-HL2 Function: Hood lights (use a dedicated branch circuit) 120-220 VAC / 1PH / 50-60HZ, 12A (maximum load) 12-14AWG, 7.1 lb-in (0.8Nm), Stripping length: 3/8" (9.5mm)
	Output 1	Terminals HL3-HL4 Function: Hood lights 120-220 VAC / 1PH / 50-60HZ, 12A (maximum load) 12-14AWG, 7.1 lb-in (0.8Nm), Stripping length: 3/8" (9.5mm)
Low Voltage Connections	Wiring Terminals	16 to 18AWG, Copper conductors only, Stranded or solid core, 75degC Stripping length: 0.25" (6mm) Tightening Torque: 3.5lb-in (0.5Nm) Field wiring: Class 2 circuits. Use shielded 75degC Plenum rated cables.
	FA1-FA2	Hood Fire Suppression System Interlock to ECOAZUR® N.C. contact. Wire in series when more than one system.
	BY1-BY2	VFD on Bypass Interlock to ECOAZUR® N.O. contact. Wire in parallel when more than one system.
	PT1	PT1: Exhaust fan1 - Main exhaust duct static pressure (0-10V)
	5 Digital Inputs	CU processor configurable digital inputs (DI1...DI5) 24VDC
	3 Digital Outputs	CU processor configurable digital outputs (DO1...DO3) Solid State Relay (24V AC/DC, 100mA max.)
	Hood Sensor Network	CU processor RJ45 communication input ports (CI1...CI6) Individually fused (non-replaceable). Connects to ECOAZUR® sensors, keypads and hubs. <u>Use V4NF series cables only.</u> Each port provides diagnostic indicators <ul style="list-style-type: none"> - Green LED: 24V status - Orange LED: communication status Ports are universal, except when connected to V4IB1 optic sensors: <ul style="list-style-type: none"> - CI1 & CI2 form a first optic sensor pair

	<ul style="list-style-type: none"> - CI3 & CI4 form a second optic sensor pair - Both optic sensor pairs may be in line of sight with each other and do not interfere with one another.
4 Output Channels	<p>Configurable output channels 4 DO, 4 AO Used to control equipment such as VFDs, ECMs, MD dampers or BAS signals. AO1...AO4: Analog Output, 0-10V (configurable, 4-point linearization) DO1...DO4: Digital Output, Solid State Relay (24V AC/DC, 100mA max.)* AC1: 24VAC 50-60Hz 100VA Class 2, max. 4 MD dampers <i>*DO1 is equipped with and interposing relay to interlock a make-up air control logic (24-220V, 6A max. load) (N.O. contact wired to "M1-1" & "M1-2")</i></p>
Ambient Limits	Temperature: 41 to 131 deg F (5 to 55 deg C) Indoor location
Enclosure material	Painted Steel
Enclosure type	4
Weight	39.8 lb (18.1 kg)

Agency Listing



- Conforms to ANSI/UL Standard 508A, Industrial Control panels.
- Certified to CAN/CSA Standard C22.2 No. 14, Industrial Control Equipment
- Conforms to ANSI/UL Standard 2017, Safety General-Purpose Signaling Devices and Systems.
- Certified to CAN/CSA Standard C22.2 No. 205, Signal Equipment

Dimensions

Height (H) 20" (508 mm)
Width (W) 16" (406 mm)
Depth (D) 6" (152mm)



V4PP04PLUS1
Processor Panel
(No openings)

Maintenance

- No maintenance required.

V4PP08PLUS1

ECOAZUR® Plus Processor Panel, 8 Output Channels

PROCESSOR PANELS

Functional Description



The ECOAZUR® DCKV is a modular system designed to match complex kitchen ventilation applications as well as simple installations. The V4PP08PLUS1 processor panel may host up to 75 ECOAZUR® intelligent hood sensors, sensor hubs and keypads while controlling a combined total of 8 exhaust/supply fans and modulating dampers (MD).

- Controls hood ventilation and hood lights automatically
- Controls the main exhaust duct static pressure
- Designed to work with ABB ACH550/ACS320 VFDs and V4MD2 fast-running damper actuators
- Includes one (1) V4CU1, two (2) V4TC1 and 24V supply for 8 MD actuators
- Should the hood fire suppression system be released or a VFD be on BYPASS, all modulating dampers are interlocked to a fail-safe open position within 4 seconds
- Typically located in the kitchen above the ceiling or in the electrical room

Specifications

Electrical Rating	Input 1	Terminals L-N Function: DCKV controls (use a dedicated branch circuit) 120-220 VAC / 1 PH / 50-60HZ, 2.2-1.2A 12-14AWG, 7.1 lb-in (0.8Nm), Stripping length: 3/8" (9.5mm)
	Input 2	Terminals HL1-HL2 Function: Hood lights (use a dedicated branch circuit) 120-220 VAC / 1PH / 50-60HZ, 12A (maximum load) 12-14AWG, 7.1 lb-in (0.8Nm), Stripping length: 3/8" (9.5mm)
	Output 1	Terminals HL3-HL4 Function: Hood lights 120-220 VAC / 1PH / 50-60HZ, 12A (maximum load) 12-14AWG, 7.1 lb-in (0.8Nm), Stripping length: 3/8" (9.5mm)
Low Voltage Connections	Wiring Terminals	16 to 18AWG, Copper conductors only, Stranded or solid core, 75degC Stripping length: 0.25" (6mm) Tightening Torque: 3.5lb-in (0.5Nm) Field wiring: Class 2 circuits. Use shielded 75degC Plenum rated cables.
	FA1-FA2	Hood Fire Suppression System Interlock to ECOAZUR® N.C. contact. Wire in series when more than one system.
	BY1-BY2	VFD on Bypass Interlock to ECOAZUR® N.O. contact. Wire in parallel when more than one system.
	PT1...PT2	PT1: Exhaust fan 1 - Main exhaust duct static pressure (0-10V) PT2: Exhaust fan 2- Main exhaust duct static pressure (0-10V)
	5 Digital Inputs	CU processor configurable digital inputs (DI1...DI5) 24VDC
	3 Digital Outputs	CU processor configurable digital outputs (DO1...DO3) Solid State Relay (24V AC/DC, 100mA max.)
	Hood Sensor Network	CU processor RJ45 communication input ports (CI1...CI6) Individually fused (non-replaceable). Connects to ECOAZUR® sensors, keypads and hubs. <u>Use V4NF series cables only.</u> Each port provides diagnostic indicators <ul style="list-style-type: none"> - Green LED: 24V status - Orange LED: communication status Ports are universal, except when connected to V4IB1 optic sensors: <ul style="list-style-type: none"> - CI1 & CI2 form a first optic sensor pair

	<ul style="list-style-type: none"> - CI3 & CI4 form a second optic sensor pair - Both optic sensor pairs may be in line of sight with each other and do not interfere with one another.
8 Output Channels	<p>Configurable output channels 8 DO, 8 AO Used to control equipment such as VFDs, ECMs, MD dampers or BAS signals. AO1...AO8: Analog Output, 0-10V (configurable, 4-point linearization) DO1...DO8: Digital Output, Solid State Relay (24V AC/DC, 100mA max.)* AC1...AC2: 24VAC 50-60Hz 100VA Class 2, max. 4 MD dampers per circuit <i>*DO1 is equipped with and interposing relay to interlock a make-up air control logic (24-220V, 6A max. load) (N.O. contact wired to "M1-1" & "M1-2")</i></p>
Ambient Limits	Temperature: 41 to 131 deg F (5 to 55 deg C) Indoor location
Enclosure material	Painted Steel
Enclosure type	4
Weight	61.0 lb (27.7 kg)

Agency Listing



- Conforms to ANSI/UL Standard 508A, Industrial Control panels.
- Certified to CAN/CSA Standard C22.2 No. 14, Industrial Control Equipment
- Conforms to ANSI/UL Standard 2017, Safety General-Purpose Signaling Devices and Systems.
- Certified to CAN/CSA Standard C22.2 No. 205, Signal Equipment

Dimensions

Height (H) 24" (610 mm)
Width (W) 20" (508 mm)
Depth (D) 6" (152mm)



V4PP08PLUS1
Processor Panel
(No openings)

Maintenance

- No maintenance required.

V4PP12PLUS1

ECOAZUR® Plus Processor Panel, 12 Output Channels

PROCESSOR PANELS

Functional Description



The ECOAZUR® DCKV is a modular system designed to match complex kitchen ventilation applications as well as simple installations. The V4PP12PLUS1 processor panel may host up to 75 ECOAZUR® intelligent hood sensors, sensor hubs and keypads while controlling a combined total of 12 exhaust/supply fans and modulating dampers (MD).

- Controls hood ventilation and hood lights automatically
- Controls the main exhaust duct static pressure
- Designed to work with ABB ACH550/ACS320 VFDs and V4MD2 fast-running damper actuators
- Includes one (1) V4CU1, three (3) V4TC1 and 24V supply for 12 MD actuators
- Should the hood fire suppression system be released or a VFD be on BYPASS, all modulating dampers are interlocked to a fail-safe open position within 4 seconds
- Typically located in the kitchen above the ceiling or in the electrical room

Specifications

Electrical Rating	Input 1	Terminals L-N Function: DCKV controls (use a dedicated branch circuit) 120-220 VAC / 1 PH / 50-60HZ, 3.0-1.7A 12-14AWG, 7.1 lb-in (0.8Nm), Stripping length: 3/8" (9.5mm)
	Input 2	Terminals HL1-HL2 Function: Hood lights (use a dedicated branch circuit) 120-220 VAC / 1PH / 50-60HZ, 12A (maximum load) 12-14AWG, 7.1 lb-in (0.8Nm), Stripping length: 3/8" (9.5mm)
	Output 1	Terminals HL3-HL4 Function: Hood lights 120-220 VAC / 1PH / 50-60HZ, 12A (maximum load) 12-14AWG, 7.1 lb-in (0.8Nm), Stripping length: 3/8" (9.5mm)
Low Voltage Connections	Wiring Terminals	16 to 18AWG, Copper conductors only, Stranded or solid core, 75degC Stripping length: 0.25" (6mm) Tightening Torque: 3.5lb-in (0.5Nm) Field wiring: Class 2 circuits. Use shielded 75degC Plenum rated cables.
	FA1-FA2	Hood Fire Suppression System Interlock to ECOAZUR® N.C. contact. Wire in series when more than one system.
	BY1-BY2	VFD on Bypass Interlock to ECOAZUR® N.O. contact. Wire in parallel when more than one system.
	PT1...PT3	PT1: Exhaust fan 1 - Main exhaust duct static pressure (0-10V) PT2: Exhaust fan 2- Main exhaust duct static pressure (0-10V) PT3: Exhaust fan 3 - Main exhaust duct static pressure (0-10V)
	5 Digital Inputs	CU processor configurable digital inputs (DI1...DI5) 24VDC
	3 Digital Outputs	CU processor configurable digital outputs (DO1...DO3) Solid State Relay (24V AC/DC, 100mA max.)
	Hood Sensor Network	CU processor RJ45 communication input ports (CI1...CI6) Individually fused (non-replaceable). Connects to ECOAZUR® sensors, keypads and hubs. <u>Use V4NF series cables only.</u> Each port provides diagnostic indicators <ul style="list-style-type: none"> - Green LED: 24V status - Orange LED: communication status Ports are universal, except when connected to V4IB1 optic sensors: <ul style="list-style-type: none"> - CI1 & CI2 form a first optic sensor pair

	- CI3 & CI4 form a second optic sensor pair Both optic sensor pairs may be in line of sight with each other and do not interfere with one another.
12 Output Channels	Configurable output channels 12 DO, 12 AO Used to control equipment such as VFDs, ECMs, MD dampers or BAS signals. AO1...AO12: Analog Output, 0-10V (configurable, 4-point linearization) DO1...DO12: Digital Output, Solid State Relay (24V AC/DC, 100mA max.)* AC1..AC3: 24VAC 50-60Hz 100VA Class 2, max. 4 MD dampers per circuit <i>*DO1 is equipped with and interposing relay to interlock a make-up air control logic (24-220V, 6A max. load) (N.O. contact wired to "M1-1" & "M1-2")</i>
Ambient Limits	Temperature: 41 to 131 deg F (5 to 55 deg C) Indoor location
Enclosure material	Painted Steel
Enclosure type	4
Weight	81.0 lb (36.7 kg)

Agency Listing



- Conforms to ANSI/UL Standard 508A, Industrial Control panels.
- Certified to CAN/CSA Standard C22.2 No. 14, Industrial Control Equipment
- Conforms to ANSI/UL Standard 2017, Safety General-Purpose Signaling Devices and Systems.
- Certified to CAN/CSA Standard C22.2 No. 205, Signal Equipment

Dimensions

Height (H) 24" (610 mm)
Width (W) 24" (610 mm)
Depth (D) 6" (152mm)



V4PP12PLUS1
Processor Panel
(No openings)

Maintenance

- No maintenance required.

V4PP16PLUS1

ECOAZUR® Plus Processor Panel, 16 Output Channels

PROCESSOR PANELS

Functional Description



The ECOAZUR® DCKV is a modular system designed to match complex kitchen ventilation applications as well as simple installations. The V4PP16PLUS1 processor panel may host up to 75 ECOAZUR® intelligent hood sensors, sensor hubs and keypads while controlling a combined total of 16 exhaust/supply fans and modulating dampers (MD).

- Controls hood ventilation and hood lights automatically
- Controls the main exhaust duct static pressure
- Designed to work with ABB ACH550/ACS320 VFDs and V4MD2 fast-running damper actuators
- Includes one (1) V4CU1, four (4) V4TC1 and 24V supply for 16 MD actuators
- Should the hood fire suppression system be released or a VFD be on BYPASS, all modulating dampers are interlocked to a fail-safe open position within 4 seconds
- Typically located in the kitchen above the ceiling or in the electrical room

Specifications

Electrical Rating	Input 1	Terminals L-N Function: DCKV controls (use a dedicated branch circuit) 120-220 VAC / 1 PH / 50-60HZ, 3.9-2.1A 12-14AWG, 7.1 lb-in (0.8Nm), Stripping length: 3/8" (9.5mm)
	Input 2	Terminals HL1-HL2 Function: Hood lights (use a dedicated branch circuit) 120-220 VAC / 1PH / 50-60HZ, 12A (maximum load) 12-14AWG, 7.1 lb-in (0.8Nm), Stripping length: 3/8" (9.5mm)
	Output 1	Terminals HL3-HL4 Function: Hood lights 120-220 VAC / 1PH / 50-60HZ, 12A (maximum load) 12-14AWG, 7.1 lb-in (0.8Nm), Stripping length: 3/8" (9.5mm)
Low Voltage Connections	Wiring Terminals	16 to 18AWG, Copper conductors only, Stranded or solid core, 75degC Stripping length: 0.25" (6mm) Tightening Torque: 3.5lb-in (0.5Nm) Field wiring: Class 2 circuits. Use shielded 75degC Plenum rated cables.
	FA1-FA2	Hood Fire Suppression System Interlock to ECOAZUR® N.C. contact. Wire in series when more than one system.
	BY1-BY2	VFD on Bypass Interlock to ECOAZUR® N.O. contact. Wire in parallel when more than one system.
	PT1...PT4	PT1: Exhaust fan 1 - Main exhaust duct static pressure (0-10V) PT2: Exhaust fan 2 - Main exhaust duct static pressure (0-10V) PT3: Exhaust fan 3 - Main exhaust duct static pressure (0-10V) PT4: Exhaust fan 4 - Main exhaust duct static pressure (0-10V)
	5 Digital Inputs	CU processor configurable digital inputs (DI1...DI5) 24VDC
	3 Digital Outputs	CU processor configurable digital outputs (DO1...DO3) Solid State Relay (24V AC/DC, 100mA max.)
	Hood Sensor Network	CU processor RJ45 communication input ports (CI1...CI6) Individually fused (non-replaceable). Connects to ECOAZUR® sensors, keypads and hubs. <u>Use V4NF series cables only.</u> Each port provides diagnostic indicators <ul style="list-style-type: none"> - Green LED: 24V status - Orange LED: communication status

Ports are universal, except when connected to V4IB1 optic sensors:

- CI1 & CI2 form a first optic sensor pair
- CI3 & CI4 form a second optic sensor pair
- Both optic sensor pairs may be in line of sight with each other and do not interfere with one another.

16 Output Channels

Configurable output channels 16 DO, 16 AO
Used to control equipment such as VFDs, ECMs, MD dampers or BAS signals.
AO1...AO16: Analog Output, 0-10V (configurable, 4-point linearization)
DO1...DO16: Digital Output, Solid State Relay (24V AC/DC, 100mA max.)*
AC1...AC4: 24VAC 50-60Hz 100VA Class 2, max. 4 MD dampers per circuit
**DO1 is equipped with and interposing relay to interlock a make-up air control logic (24-220V, 6A max. load) (N.O. contact wired to "M1-1" & "M1-2")*

Ambient Limits Temperature: 41 to 131 deg F (5 to 55 deg C)
Indoor location

Enclosure material Painted Steel

Enclosure type 4

Weight 85.4 lb (38.7 kg)

Agency Listing



- Conforms to ANSI/UL Standard 508A, Industrial Control panels.
- Certified to CAN/CSA Standard C22.2 No. 14, Industrial Control Equipment
- Conforms to ANSI/UL Standard 2017, Safety General-Purpose Signaling Devices and Systems.
- Certified to CAN/CSA Standard C22.2 No. 205, Signal Equipment

Dimensions

Height (H) 24" (610 mm)
Width (W) 24" (610 mm)
Depth (D) 6" (152mm)



V4PP16PLUS1
Processor Panel
(No openings)

Maintenance

- No maintenance required.

V4PP20PLUS1

ECOAZUR® Plus Processor Panel, 20 Output Channels

PROCESSOR PANELS

Functional Description



The ECOAZUR® DCKV is a modular system designed to match complex kitchen ventilation applications as well as simple installations. The V4PP20PLUS1 processor panel may host up to 75 ECOAZUR® intelligent hood sensors, sensor hubs and keypads while controlling a combined total of 20 exhaust/supply fans and modulating dampers (MD).

- Controls hood ventilation and hood lights automatically
- Controls the main exhaust duct static pressure
- Designed to work with ABB ACH550/ACS320 VFDs and V4MD2 fast-running damper actuators
- Includes one (1) V4CU1, five (5) V4TC1 and 24V supply for 20 MD actuators
- Should the hood fire suppression system be released or a VFD be on BYPASS, all modulating dampers are interlocked to a fail-safe open position within 4 seconds
- Typically located in the kitchen above the ceiling or in the electrical room

Specifications

Electrical Rating	Input 1	Terminals L-N Function: DCKV controls (use a dedicated branch circuit) 120-220 VAC / 1 PH / 50-60HZ, 4.7-2.6A 12-14AWG, 7.1 lb-in (0.8Nm), Stripping length: 3/8" (9.5mm)
	Input 2	Terminals HL1-HL2 Function: Hood lights (use a dedicated branch circuit) 120-220 VAC / 1PH / 50-60HZ, 12A (maximum load) 12-14AWG, 7.1 lb-in (0.8Nm), Stripping length: 3/8" (9.5mm)
	Output 1	Terminals HL3-HL4 Function: Hood lights 120-220 VAC / 1PH / 50-60HZ, 12A (maximum load) 12-14AWG, 7.1 lb-in (0.8Nm), Stripping length: 3/8" (9.5mm)
Low Voltage Connections	Wiring Terminals	16 to 18AWG, Copper conductors only, Stranded or solid core, 75degC Stripping length: 0.25" (6mm) Tightening Torque: 3.5lb-in (0.5Nm) Field wiring: Class 2 circuits. Use shielded 75degC Plenum rated cables.
	FA1-FA2	Hood Fire Suppression System Interlock to ECOAZUR® N.C. contact. Wire in series when more than one system.
	BY1-BY2	VFD on Bypass Interlock to ECOAZUR® N.O. contact. Wire in parallel when more than one system.
	PT1...PT4	PT1: Exhaust fan 1 - Main exhaust duct static pressure (0-10V) PT2: Exhaust fan 2 - Main exhaust duct static pressure (0-10V) PT3: Exhaust fan 3 - Main exhaust duct static pressure (0-10V) PT4: Exhaust fan 4 - Main exhaust duct static pressure (0-10V)
	5 Digital Inputs	CU processor configurable digital inputs (DI1...DI5) 24VDC
	3 Digital Outputs	CU processor configurable digital outputs (DO1...DO3) Solid State Relay (24V AC/DC, 100mA max.)
	Hood Sensor Network	CU processor RJ45 communication input ports (CI1...CI6) Individually fused (non-replaceable). Connects to ECOAZUR® sensors, keypads and hubs. <u>Use V4NF series cables only.</u> Each port provides diagnostic indicators <ul style="list-style-type: none"> - Green LED: 24V status - Orange LED: communication status

	Ports are universal, except when connected to V4IB1 optic sensors: <ul style="list-style-type: none"> - CI1 & CI2 form a first optic sensor pair - CI3 & CI4 form a second optic sensor pair - Both optic sensor pairs may be in line of sight with each other and do not interfere with one another.
20 Output Channels	Configurable output channels 20 DO, 20 AO Used to control equipment such as VFDs, ECMs, MD dampers or BAS signals. AO1...AO20: Analog Output, 0-10V (configurable, 4-point linearization) DO1...DO20: Digital Output, Solid State Relay (24V AC/DC, 100mA max.)* AC1...AC5: 24VAC 50-60Hz 100VA Class 2, max. 4 MD dampers per circuit <i>*DO1 is equipped with and interposing relay to interlock a make-up air control logic (24-220V, 6A max. load) (N.O. contact wired to "M1-1" & "M1-2")</i>
Ambient Limits	Temperature: 41 to 131 deg F (5 to 55 deg C) Indoor location
Enclosure material	Painted Steel
Enclosure type	4
Weight	96.8 lb (43.9 kg)

Agency Listing



- Conforms to ANSI/UL Standard 508A, Industrial Control panels.
- Certified to CAN/CSA Standard C22.2 No. 14, Industrial Control Equipment
- Conforms to ANSI/UL Standard 2017, Safety General-Purpose Signaling Devices and Systems.
- Certified to CAN/CSA Standard C22.2 No. 205, Signal Equipment

Dimensions

- Height (H)** 30" (762 mm)
- Width (W)** 24" (610 mm)
- Depth (D)** 6" (152mm)

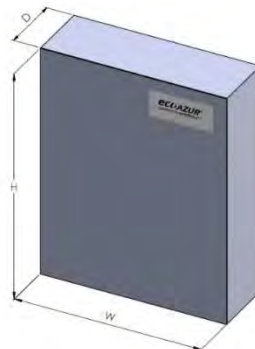

V4PP20PLUS1
Processor Panel
(No openings)

Maintenance

- No maintenance required.

V4CU1

ECOAZUR® Processor, Panel Mount

CONTROL MODULES

Functional Description



The ECOAZUR® processor unit is the central node in the ECOAZUR DCKV system:

- hosts up to 75 ECOAZUR® intelligent hood sensors, hubs and keypads
- hosts up to 5 TC output modules, supporting a combined total of 20 exhaust/supply and modulating dampers (MD).
- interfaces with the Building Automation System
- controls the hood light relay
- interlocks with the Hood Fire Suppression system
- interfaces with optional ECOAZUR® Cloud Platform

The V4CU1 processor is included in all processor panel series (LITE, STD & PLUS) and may also be integrated in a UL 508A listed third-party control panel.

All RJ45 Network ports (CI & CO) offer visual indication of 24V power status (green LED) and communication status (orange LED)

Specifications

Power Supply	24 VDC, 60W, UL 1310 Class 2 rated power supply. Use a Delta DRP024V060W1NZ Supply circuit must be grounded using a clean Earth Ground.
Wiring	16 to 18AWG, Copper conductors only, Stranded or solid core, 75degC Field wiring: Class 2 circuits, wire separately from other electrical circuits. Use shielded 75degC Plenum rated cables.
Terminals	Stripping length: 0.25" (6mm) Tightening Torque: 3.5lb-in (0.5Nm)
Low Voltage Connections	<p>CU processor configurable digital inputs (DI1...DI5):</p> <p><u>Terminals 10-11:</u> DI1 – 24VDC Contact input, Default function: Fire Hood Fire Suppression System Interlock to ECOAZUR® N.C. contact. Wire contacts in series when more than one system.</p> <p><u>Terminals 12-13:</u> DI2 – 24VDC Contact input, Default function: No function*</p> <p><u>Terminals 14-15:</u> DI3 – 24VDC Contact input, Default function: No function*</p> <p><u>Terminals 16-17:</u> DI4 – 24VDC Contact input, Default function: No function*</p> <p><u>Terminals 18-19:</u> DI5 – 24VDC Contact input, Default function: No function*</p> <p>*DI2-DI5 are available to the BAS systems, or any third-party device, to request/force ventilation modes (MAX, AUTO, SCHEDULE, VFD in BYPASS, etc.)</p> <p>CU processor configurable digital outputs (DO1...DO3):</p> <p><u>Terminals 22-23:</u> DO1 – Solid State Output (24V AC/DC, 100mA max.) Default function: Hood Lights</p> <p><u>Terminals 24-25:</u> DO2 – Solid State Output (24V AC/DC, 100mA max.) Default function: Auto Mode</p> <p><u>Terminals 26-27:</u> DO3 – Solid State Output (24V AC/DC, 100mA max.) Default function: Warning/Alarm (N.C.)</p> <p>Communication Input Ports (CI1...CI6):</p> <p>Six (6) RJ45 communication ports. Individually fused (non-replaceable). Connects to ECOAZUR® sensors, keypads and hubs. <u>Use V4NF series cables only.</u> Each port provides diagnostic indicators</p> <ul style="list-style-type: none"> - Green LED: 24V status - Orange LED: communication status <p>Ports are universal, except when connected to V4IB1 optic sensors:</p> <ul style="list-style-type: none"> - CI1 & CI2 form a first optic sensor pair

- CI3 & CI4 form a second optic sensor pair
- Both optic sensor pairs may be in line of sight with each other and do not interfere with one another

Communication Output Ports (CO):

One (1) RJ45 communication Output port (replaceable fuse below cover).

Use V4NF series cables only.

TC Modules may also be connected using terminals 30-31-32-33

Port diagnostic indicator:

- Green LED: 24V status
- Orange LED: communication status

A CU processor may control up to five (5) TC output modules.

Ambient Limits	Temperature: 41 to 131 deg F (5 to 55 deg C) Humidity: 10% to 90% RH non-condensing
Mounting	Panel mount, four (4) #8 clearance holes
Weight	0.6 lb (0.3 kg)

Agency Listing



Listed as part of the ECOAZUR® DCKV Control System:

- Conforms to ANSI/UL Standard 2017, Safety General-Purpose Signaling Devices and Systems.
- Certified to CAN/CSA Standard C22.2 No. 205, Signal Equipment

Dimensions

Length (L)	5.8" (148 mm)
Width (W)	3.9" (98 mm)
Height (H)	2.1" (53 mm)

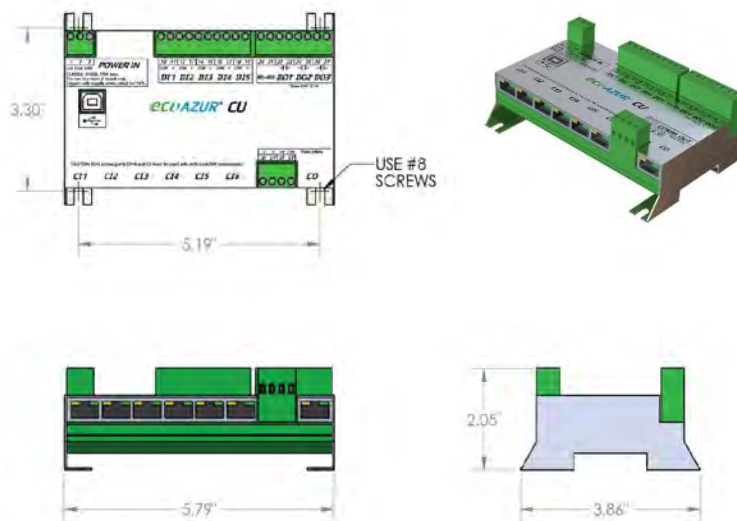

Maintenance

- No maintenance required.

V4TC1

ECOAZUR® 4 Channel Output Module, Panel-mount

CONTROL MODULES

Functional Description

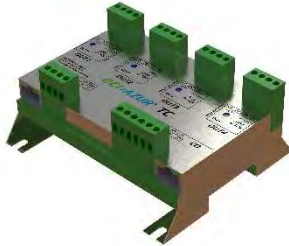

The V4TC1 output module (TC) is an intelligent network component consisting of four (4) output channels designed to interface the ECOAZUR® processor to ventilation equipment such as VFDs, ECMs, ECOAZUR® modulating dampers or BAS signals. Each output channel consists of :

- a 0-10V analog output (modulation signal)
- a digital output (start/stop signal)

The ECOAZUR Processor may host up to five (5) TC modules, supporting a combined total of 20 exhaust, supply fans or modulating dampers (MD). Modulating damper electrical power is not supplied by the V4TC1 module.

Both RJ45 Network ports (CI & CO) offer visual indication of 24V power status (green LED) and communication status (orange LED). All four output channels offer visual indication of the start/stop status (blue LED).

Specifications

Power Supply	24 VDC, Class 2 power source through V4NF network cable (CI Port or term. # 3-4)
Power Consumption	1.2 W
Wiring	16 to 18AWG, Copper conductors only, Stranded or solid core, 75degC Field wiring: Class 2 circuits, wire separately from other electrical circuits. Use shielded 75degC Plenum rated cables.
Terminals	Stripping length: 0.25" (6mm) Tightening Torque: 3.5lb-in (0.5Nm)
Low Voltage Connections	<u>CI Port: Communication Input</u> 1 RJ45 port (use V4NF series network cables only), or Terminals 1-2-3-4 Connects to one of the following: <ul style="list-style-type: none"> - the CO port of the CU Processor - the CO port of another TC Output Module <u>CO Port: Communication Output</u> 1 RJ45 port (use V4NF series network cables only), or Terminals 7-8-9-10 Connects to the CI port of another TC Output Module <u>Terminals 11-12:</u> Channel 1, Solid State Output, 24V 100mA Max* <u>Terminals 13-14:</u> Channel 1, 0-10V Output, 4-point characterization (% to Voltage) <u>Terminals 15-16:</u> Channel 2, Solid State Output, 24V 100mA Max* <u>Terminals 17-18:</u> Channel 2, 0-10V Output, 4-point characterization (% to Voltage) <u>Terminals 19-20:</u> Channel 3, Solid State Output, 24V 100mA Max* <u>Terminals 21-22:</u> Channel 3, 0-10V Output, 4-point characterization (% to Voltage) <u>Terminals 23-24:</u> Channel 4, Solid State Output, 24V 100mA Max* <u>Terminals 25-26:</u> Channel 4, 0-10V Output, 4-point characterization (% to Voltage) *Use interposing relays when interlocking a control circuit exceeding specifications.
Ambient Limits	Temperature: 41 to 131 deg F (5 to 55 deg C) Humidity: 10% to 90% RH non-condensing
Mounting	Panel mount, four (4) #8 clearance holes
Weight	0.6 lb (0.3 kg)

Agency Listing



Listed as part of the ECOAZUR® DCKV Control System:

- Conforms to ANSI/UL Standard 2017, Safety General-Purpose Signaling Devices and Systems.
- Certified to CAN/CSA Standard C22.2 No. 205, Signal Equipment

Dimensions

Length (L) 5.0" (127 mm)
Width (W) 3.9" (98 mm)
Height (H) 2.1" (53 mm)

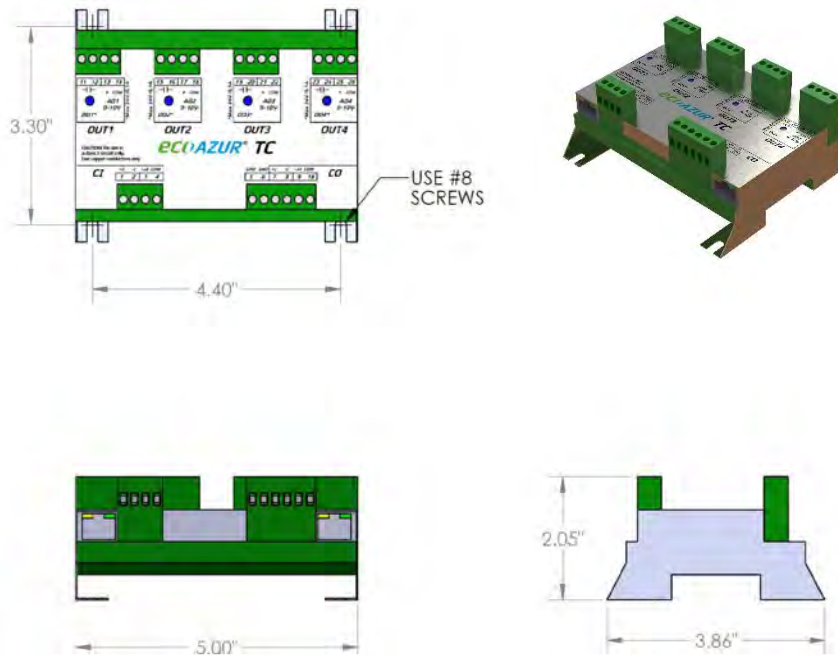

Maintenance

- No maintenance required.

V4NE1

ECOAZUR® Hood Sensor Network Hub, Panel Mount

CONTROL MODULES

Functional Description

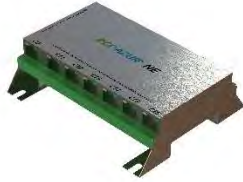

The V4NE1 hood sensor hub expands the ECOAZUR® processor network connection capabilities while minimizing overall installation time and costs.

- Mounts on top of a hood and provides a means of connecting a total of six (6) ECOAZUR® components, including ECOAZUR® sensors, keypads and hubs.
- Offers easy diagnostic: every RJ45 port indicates 24V status (green LED) and communication status (orange LED).
- Panel mount support brackets

Specifications

Power Supply	24 VDC, Class 2 power source (through V4NF network cable)
Power Consumption	0.8 W
Low Voltage Connections	<p>Communication Input Ports (CI1...CI6): Six (6) RJ45 communication ports. Connects to ECOAZUR® sensors, keypads and hubs. <u>Use V4NF series cables only.</u> Each port provides diagnostic indicators:</p> <ul style="list-style-type: none"> - Green LED: 24V status - Orange LED: communication status <p>Ports are universal, except when connected to V4IB1 optic sensors:</p> <ul style="list-style-type: none"> - CI1 & CI2 form a first optic sensor pair - CI3 & CI4 form a second optic sensor pair <p>Both optic sensor pairs may be in line of sight with each other and do not interfere with one another.</p> <p>Communication Output (CO): RJ45 communication port: <u>use V4NF series cables only</u> Each port provides diagnostic indicators</p> <ul style="list-style-type: none"> - Green LED: 24V status - Orange LED: communication status <p>Connects to one of the following:</p> <ul style="list-style-type: none"> - V4CU1 processor, ports CI1...CI6. - V4NE series network hub, ports CI1...CI6
Ambient Limits	Temperature: 41 to 131 deg F (5 to 55 deg C) Humidity: 10% to 90% RH non-condensing
Mounting	Panel mount, four (4) #8 clearance holes
Weight	0.5 lb (0.2 kg)

Agency Listing



Listed as part of the ECOAZUR® DCKV Control System:

- Conforms to ANSI/UL Standard 2017, Safety General-Purpose Signaling Devices and Systems.
- Certified to CAN/CSA Standard C22.2 No. 205, Signal Equipment

Dimensions

Length (L) 5.0" (127 mm)
Width (W) 3.9" (98 mm)
Height (H) 1.5" (53 mm)

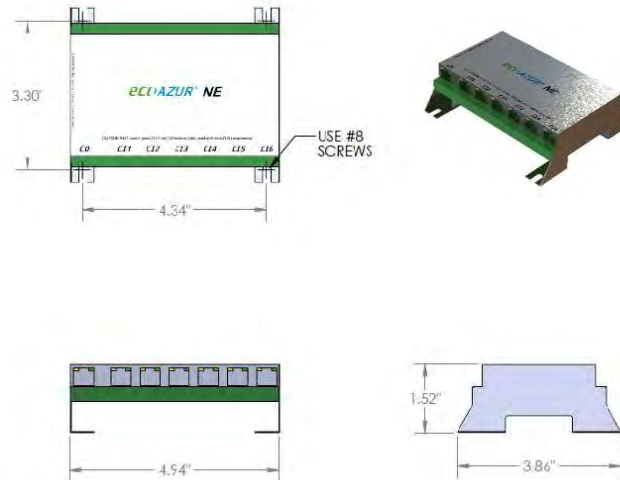

Maintenance

- No maintenance required.
-

V4NE2

ECOAZUR® Hood Sensor Network Hub with enclosure

CONTROL MODULES

Functional Description



The V4NE2 hood sensor hub expands the ECOAZUR® processor network connection capabilities while minimizing overall installation time and costs.

- Mounts on top of a hood and provides a means of connecting a total of six (6) ECOAZUR® components, including ECOAZUR® sensors, keypads and hubs.
- Offers easy diagnostic: every RJ45 port indicates 24V status (green LED) and communication status (orange LED).
- Accommodates 3/4" electrical conduit through various cut-outs.
- Extra space is available within the enclosure to coil and store excess cable.

Specifications

Power Supply	24 VDC, Class 2 power source (through V4NF network cable)
Power Consumption	0.8 W
Low Voltage Connections	<p>Communication Input Ports (CI1...CI6): Six (6) RJ45 communication ports. Connects to ECOAZUR® sensors, keypads and hubs. <u>Use V4NF series cables only.</u> Each port provides diagnostic indicators:</p> <ul style="list-style-type: none"> - Green LED: 24V status - Orange LED: communication status <p>Ports are universal, except when connected to V4IB1 optic sensors:</p> <ul style="list-style-type: none"> - CI1 & CI2 form a first optic sensor pair - CI3 & CI4 form a second optic sensor pair <p>Both optic sensor pairs may be in line of sight with each other and do not interfere with one another.</p> <p>Communication Output (CO): RJ45 communication port: <u>use V4NF series cables only</u> Each port provides diagnostic indicators</p> <ul style="list-style-type: none"> - Green LED: 24V status - Orange LED: communication status <p>Connects to one of the following :</p> <ul style="list-style-type: none"> - V4CU1 processor, ports CI1...CI6. - V4NE series network hub, ports CI1...CI6
Ambient Limits	Temperature: 41 to 131 deg F (5 to 55 deg C) Humidity: 10% to 90% RH non-condensing
Enclosure material	Galvanized Steel
Weight	5.8 lb (2.7 kg)

Agency Listing



Listed as part of the ECOAZUR® DCKV Control System:

- Conforms to ANSI/UL Standard 2017, Safety General-Purpose Signaling Devices and Systems.
- Certified to CAN/CSA Standard C22.2 No. 205, Signal Equipment

Dimensions

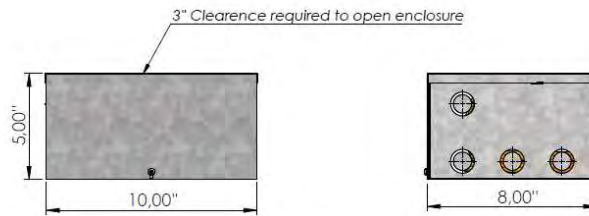
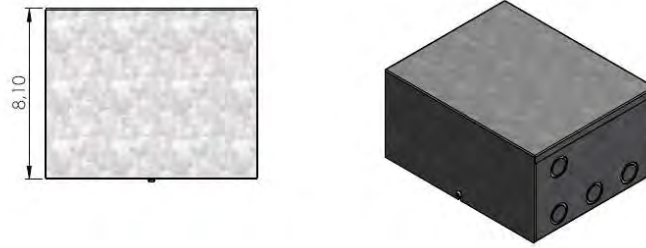

Enclosure size

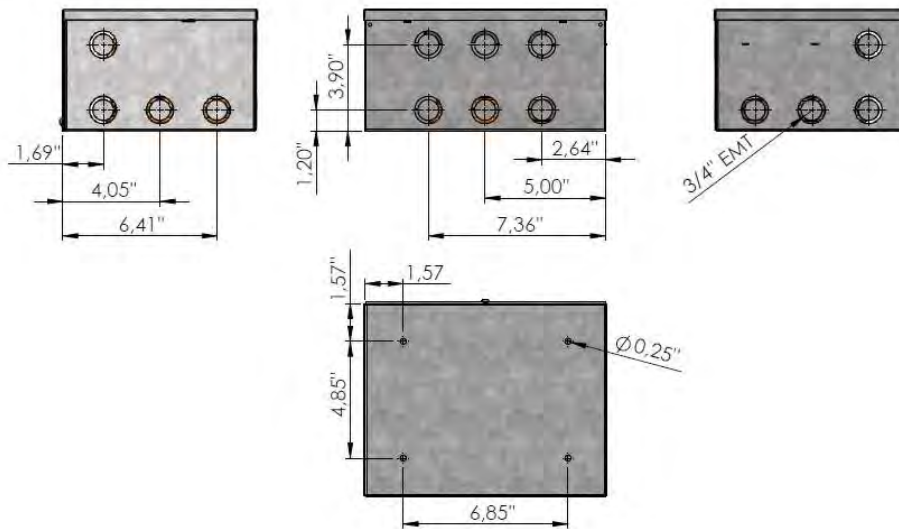

Enclosure cut-outs (right, back, left, bottom)

Maintenance

- No maintenance required.

V4CT1E

ECOAZUR® Keypad, Wall Mount

USER INTERFACE

Functional Description



The V4CT1E user interface allows the kitchen staff to see the current hood ventilation airflow rates, select ventilation modes, toggle lights and program the system. It is typically located in the kitchen area near the hood it controls.

While ECOAZUR® is designed to automatically start/stop the ventilation and hood lights, it is possible for the user to override the current operating mode from the keypad:

- MAX key: 100% airflow
- AUTO key: normal operation, leave IDLE mode
- STOP key: turns off the ventilation if no cooking is detected
- LIGHTS key: toggles hood lights state
- ECOAZUR parameters may also be configured using the keypad (password protected).

The keypad connects at any point in the hood sensor network using a V4NF cable. The cable may be routed through the superior side of the keypad (¾" electrical conduit) or through the back side (when the cable is routed through the wall).

More than one keypad may be used to control various hoods separately.

Specifications

Power Supply	24 VDC, Class 2 power source (through V4NF network cable)
Power Consumption	1.2 W
Low Voltage Connections	1 RJ45 port, use V4NF series network cables only. May connect to one of the following: -V4CU1 processor, ports CI1...CI6. -V4NE series network hub, ports CI1...CI6
Ambient Limits	Temperature: 41 to 131 deg F (5 to 55 deg C) Humidity: 10% to 90% RH non-condensing
Enclosure material	STST
Weight	1.2 lb (0.6 kg)

Agency Listing



Listed as part of the ECOAZUR® DCKV Control System:

- Conforms to ANSI/UL Standard 2017, Safety General-Purpose Signaling Devices and Systems.
- Certified to CAN/CSA Standard C22.2 No. 205, Signal Equipment

Dimensions

Height (H)	5" (127 mm)
Width (W)	5" (127 mm)
Depth (D)	1.5" (38 mm)



V4CT1E

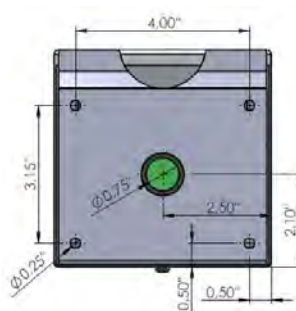

V4CT1E (wall bracket)

Maintenance

- No maintenance required.
-

V4TT2

ECOAZUR® Hood Temperature Transmitter

SENSORS

Functional Description



The ECOAZUR® V4TT2 is an intelligent sensor that measures the cooking load based on the temperature in the hood collar or canopy. Its galvanized steel enclosure is compatible with ¾" electrical conduits.

Canopy sensors are important to ensure the hood ventilation automatically starts when the cooking equipment is turned on (IMC 507.1.1). They also prevent any backdraft in the exhaust duct from delaying the start of the ventilation.

A programmable temperature span allows to adjust the desired exhaust airflow rate according to the actual cooking load. A minimum temperature is assigned to a minimum exhaust airflow rate and a maximum temperature is assigned to the maximum airflow rate. The airflow modulation range depends on the cooking equipment below the hood, the minimum velocity allowable in the exhaust ductwork and the hood sensors installed.

Typically:

- Temperature only systems have a 80-100% airflow modulation range
- Temperature + optic systems allow for a 30-100% airflow modulation range.

For best comfort and energy savings, it is recommended to use IB optic sensors in conjunction with temperature sensors.

Specifications

Power Supply	24 VDC, Class 2 power source (through V4NF network cable)
Power Consumption	0.5 W
Low Voltage Connections	RJ45 Connector, use V4NF series network cables only. May connect to a V4CU1 processor or a V4NE series hub (ports CI1...CI6).
Sensor type	10K Type III Thermistor
Ambient Limits	Probe Operating Span: -22 to 284 deg F (-30 to 140 deg C), Enclosure: 41 to 167 deg F (5 to 75 deg C), 10% to 90% RH non-condensing
Enclosure material	Galvanized Steel
Weight	1.5 lb (0.67 kg)

Agency Listing



Listed as part of the ECOAZUR® DCKV Control System:

- Conforms to ANSI/UL Standard 2017, Safety General-Purpose Signaling Devices and Systems.
- Certified to CAN/CSA Standard C22.2 No. 205, Signal Equipment
- Additionally, evaluated and found to comply with:
 - UL 1978 Clause 19 (Issued 2010/12/13 Ed:4) Fire and Leakage Test of Grease Duct Access Doors and Fittings
 - UL 710 (Issued: 2012/09/13 Ed: 6 Rev: 2013/11/05) Exhaust Hoods for Commercial Cooking Equipment
 - ULC S646 (Issued: 2010/07/01 Ed:3) Standard for Exhaust Hoods and Related Controls for Commercial and Institutional Kitchens.

Dimensions

Hood/duct cut-out diameter: 3/4" (19 mm)
Probe length: 2-3/4" (70 mm)

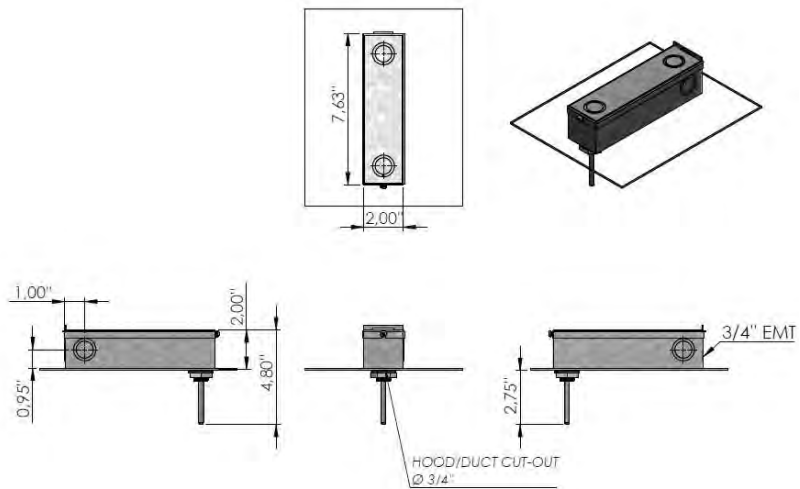

Maintenance

- Clean probe during the hood cleaning process. Refer to the User's Manual.
-

V4IB1

ECOAZUR® Hood Optic Sensor

Accessories: V4IB-TIB, V4IB-CS, V4IB-EMT & V4IB-PC

SENSORS

Functional Description



V4IB1

The IB optic sensor offers an elegant, performant and durable solution for detecting smoke or vapor generated by cooking equipment. IB sensors work in pairs, one at each end of a hood section. They perform real-time airflow setpoint calculations that are used to control a related MD exhaust damper or exhaust fan.

- A relatively wide-angle light beam and a continuous calibration algorithm ensure robust operation over a 30' (9 m) range, even as the sensor lenses become dirty.
- IB sensor diagnostic is user-friendly. Should an IB pair require attention, its blue lights will blink indicating a dirty or misaligned pair.
- A watertight STST machined enclosure allows for high sanitary standards and requires no air purge units.



V4IB-TIB series

A threaded stainless-steel mounting tube is available in three standard lengths (6", 12" & 35") and may be cut for custom applications.



V4IB-EMT

A galvanized steel enclosure protects the V4NF series network cable and is compatible with 3/4" electrical conduit.



V4IB-CS

A liquid-tight compression seal secures the V4IB-TIB mounting tube to the hood. V4IB-CS are tested and listed with Underwriters Laboratories under the classification "Hood and Duct Accessories" and meet NFPA 96 standard (section 5.1.2).



V4IB-PC

A passthrough quick seal allows the IB blue light beam to cross different hood sections. V4IB-PC are tested and listed with Underwriters Laboratories under the classification "Hood and Duct Accessories" and meet NFPA 96 standard (section 5.1.2).

Specifications

Power Supply	24 VDC, Class 2 power source (through V4NF network cable)
Power Consumption	0.8 W
Electrical Connections	RJ45 connector, use V4NF series network cables only. May connect to a V4CU1 processor or a V4NE series hub (ports CI1...CI4 only). <ul style="list-style-type: none"> - CI1 & CI2 form a first emitter/receptor pair - CI3 & CI4 form a second emitter/receptor pair - Both pairs may be in line of sight and will not interfere with one another
Ambient Limits	41 to 167 deg F (5 to 75 deg C) From within the hood: waterproof Enclosure mounted on top of the hood: 10% to 90% RH non-condensing
Enclosure material & weight	V4IB1: STST, 0.6 lb (0.29 kg) V4IB-TIB15: STST, 0.3 lb (0.14 kg) V4IB-TIB30: STST, 0.6 lb (0.25 kg) V4IB-TIB90: STST, 1.8 lb (0.82 kg) V4IB-EMT: Galvanized steel, 1.0 lb (0.45 kg) V4IB-CS: Carbon steel, nickel/chrome plate finish, 0.9 lb (0.39 kg) V4IB-PC: Carbon steel, nickel/chrome plate finish, 1.2 lb (0.55 kg)

Agency Listing



Listed as part of the ECOAZUR® DCKV Control System:

- Conforms to ANSI/UL Standard 2017, Safety General-Purpose Signaling Devices and Systems.
- Certified to CAN/CSA Standard C22.2 No. 205, Signal Equipment
- Additionally, evaluated and found to comply with:
 - UL 1978 Clause 19 (Issued 2010/12/13 Ed:4) Fire and Leakage Test of Grease Duct Access Doors and Fittings
 - UL 710 (Issued: 2012/09/13 Ed: 6 Rev: 2013/11/05) Exhaust Hoods for Commercial Cooking Equipment
 - ULC S646 (Issued: 2010/07/01 Ed:3) Standard for Exhaust Hoods and Related Controls for Commercial and Institutional Kitchens.

Dimensions

Mounting tube length (“L”):

- **V4IB-TIB15:** 6” (150 mm)
- **V4IB-TIB30:** 12” (300 mm)
- **V4IB-TIB90:** 35.4” (900 mm)

Required hood cut-out diameters:

- **V4IB-CS :** 1-3/8” (35 mm)
- **V4IB-PC :** 2-1/4” (57 mm)

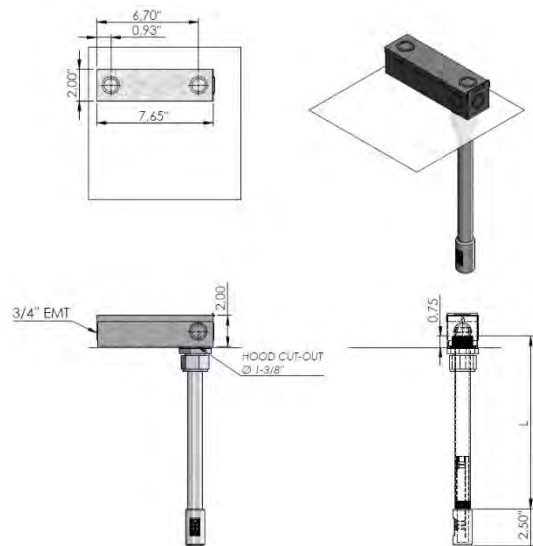

Maintenance

- Clean lens monthly or as required. Refer to the User’s Manual.

V4AS1

ECOAZUR® Analog Input Module, DIN rail

SENSORS

Functional Description



The ECOAZUR® V4AS1 is an intelligent analog input module (AS) that interfaces a third-party device to the ECOAZUR® sensor network. The AS forces a ventilation demand to exhaust fans, supply fans or modulating dampers based on a 0-10V input signal. Typical applications:

- A BAS system may force a minimum airflow to specific ventilation equipment controlled by the ECOAZUR® system (food court applications)
- A make-up air unit may require a greater airflow due to cooling/heating stages, low fire temperature rise, etc.

Specifications

Power Supply	24 VDC, Class 2 power source (through V4NF network cable)
Power Consumption	0.5 W
Low Voltage Connections	RJ45 Connector, use V4NF series network cables only. May connect to a V4CU1 processor or a V4NE series hub (ports CI1...CI6).
Signal type	0-10V, configurable sensor demand.
Ambient Limits	41 to 167 deg F (5 to 75 deg C), 10% to 90% RH non-condensing
Mounting	35mm DIN rail
Weight	0.06 lb (0.03 kg)

Agency Listing



Listed as part of the ECOAZUR® DCKV Control System:

- Conforms to ANSI/UL Standard 2017, Safety General-Purpose Signaling Devices and Systems.
- Certified to CAN/CSA Standard C22.2 No. 205, Signal Equipment

Dimensions

Height (H)	1.6" (41 mm)
Length (L)	3.3" (84 mm)
Width (W)	0.9" (23 mm)

Maintenance

- No maintenance required.

V4DS1

ECOAZUR® Digital Input Module, DIN rail

SENSORS

Functional Description



The ECOAZUR® V4DS1 is an intelligent digital input module (DS) that interfaces a third-party device to the ECOAZUR® sensor network. The DS forces a ventilation demand to exhaust fans, supply fans or modulating dampers based on a relay contact state. Four different demand levels may be activated based on the input activation time.

Typical applications:

- A BAS system may force a minimum airflow to specific ventilation equipment controlled by the ECOAZUR® system (food court applications)
- A make-up air unit may require a greater airflow due to cooling/heating stages, low fire temperature rise, etc.
- Ventilation controlled based on current switches on the electrical supply of cooking equipment, dishwashers, etc.

Specifications

Power Supply	24 VDC, Class 2 power source (through V4NF network cable)
Power Consumption	0.5 W
Low Voltage Connections	RJ45 Connector, use V4NF series network cables only.
Signal type	May connect to a V4CU1 processor or a V4NE series hub (ports CI1...CI6).
Ambient Limits	Relay contact, configurable sensor demand based on the input activation time.
Mounting	41 to 167 deg F (5 to 75 deg C), 10% to 90% RH non-condensing
Weight	35mm DIN rail
	0.06 lb (0.03 kg)

Agency Listing



Listed as part of the ECOAZUR® DCKV Control System:

- Conforms to ANSI/UL Standard 2017, Safety General-Purpose Signaling Devices and Systems.
- Certified to CAN/CSA Standard C22.2 No. 205, Signal Equipment

Dimensions

Height (H)	1.6" (41 mm)
Length (L)	3.3" (84 mm)
Width (W)	0.9" (23 mm)

Maintenance

- No maintenance required.

V4TT3

ECOAZUR® Temperature Input Module, DIN rail

SENSORS

Functional Description



The ECOAZUR® V4TT3 is an intelligent temperature input module that interfaces a third-party 10K type III thermistor to the ECOAZUR® sensor network. It allows to push additional data to the ECOAZUR® Cloud database for reporting and remote monitoring purposes:

- Kitchen ambient temperature
- Exterior temperature
- Supply air temperature

Measuring the kitchen ambient temperature also enables to start/stop the hood ventilation based on the differential temperature between the kitchen ambient space and any V4TT2 sensors installed in the hood canopy or hood collars.

Specifications

Power Supply	24 VDC, Class 2 power source (through V4NF network cable)
Power Consumption	0.5 W
Low Voltage Connections	RJ45 Connector, use V4NF series network cables only.
Sensor type	May connect to a V4CU1 processor or a V4NE series hub (ports CI1...CI6).
Ambient Limits	10K Type III Thermistor
Mounting	41 to 167 deg F (5 to 75 deg C), 10% to 90% RH non-condensing
Weight	35mm DIN rail
	0.06 lb (0.03 kg)

Agency Listing



Listed as part of the ECOAZUR® DCKV Control System:

- Conforms to ANSI/UL Standard 2017, Safety General-Purpose Signaling Devices and Systems.
- Certified to CAN/CSA Standard C22.2 No. 205, Signal Equipment

Dimensions

Height (H)	1.6" (41 mm)
Length (L)	3.3" (84 mm)
Width (W)	0.9" (23 mm)

Maintenance

- No maintenance required.

V4NF series

ECOAZUR® Hood Sensor Network Cables

CABLES

Functional Description



The V4NF series network cables (NF) are specifically designed for the ECOAZUR® DCKV application. NF cables are used to interconnect ECOAZUR intelligent devices such as hood sensors, hubs, keypads, etc. To ensure system performance and safety, only use NF cables to connect ECOAZUR® components.

NF cables are RJ45 terminated Plenum rated F/UTP network cables and must be considered as a Class 2 electrical circuit in the context of the ECOAZUR® design.

They are offered in various lengths:

Model	Length
V4NF1	1' (0.3m)
V4NF3	3' (0.9m)
V4NF5	5' (1.5m)
V4NF10	10' (3.0m)
V4NF15	15' (4.5m)
V4NF25	25' (7.5m)
V4NF50	50' (15 m)
V4NF75	75' (22 m)
V4NF100	100' (30 m)
V4NF150	150' (45 m)
V4NF200	200' (60 m)

Specifications

Conductors	CAT5E, 4 twisted pairs, 8 stranded 24AWG copper conductors.
Shield	Al Foil, drain wire
Jacket	PVC, Orange
Voltage Rating	300V
Temperature Rating	75°C
Flame test rating	UL CMP, CSA FT-6 (Plenum rated)
Nominal O.D.	0.228" (5.8mm)
Termination	RJ45, Slimline

Agency Listing



Listed as part of the ECOAZUR® DCKV Control System:

- Conforms to ANSI/UL Standard 2017, Safety General-Purpose Signaling Devices and Systems.
- Certified to CAN/CSA Standard C22.2 No. 205, Signal Equipment

Maintenance

- No maintenance required.

PATENT PENDING

V4MD2

ECOAZUR® Modulating Damper Actuator Kit, Fast-Running

MODULATING DAMPERS

Functional Description

The V4MD2 is a modulating damper actuator kit designed for commercial kitchen Type 1 and Type 2 hoods and grease ducts. The MD dampers are most advantageous when many hoods are connected to a single exhaust fan. They allow controlling the exhaust airflow rates independently at every hood section while maximising energy savings. A fast running electronic fail-safe actuator provides safe and performant operations.

The V4MD2 actuator kit is intended to be used as part of an ECOAZUR® DCKV control system, in new or retrofit applications:

- No welding is required.
- Not intended for installation on fire suppression dampers.
- Must installed with the following damper blade models (ordered separately):

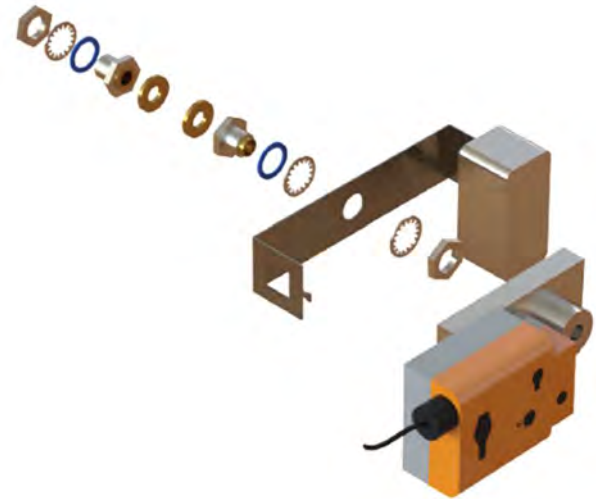

V4MD-R series
Rectangular STST blade and shaft



V4MD-C series
Circular STST blade and shaft

Specifications

Power Supply	24 VAC +/-20%, 50/60Hz, 24 VDC +/- 10%
Transformer Sizing	22 VA Class 2 power source
Electrical Connections	18 GA plenum rated cable, ½" conduit connector
Modulation	10-2V
Torque	54 in-lb (6 Nm)
Max. Damper Area	5.4 ft ² (0.5m ²)
Motor Running Time	4 seconds
Fail-Safe Running Time	4 seconds
Housing	NEMA 2, IP54, UL enclosure Type 2, UL94-5VA
Operating Temperature	32 to 122 deg F (0 to 50 deg C)
Weight	4.2 lb (1.9 kg)

Agency Listing

Listed as part of the ECOAZUR® DCKV Control System:

- Conforms to ANSI/UL Standard 2017, Safety General-Purpose Signaling Devices and Systems.
- Certified to CAN/CSA Standard C22.2 No. 205, Signal Equipment
- Additionally, evaluated and found to comply with:
 - UL 1978 Clause 19 (Issued 2010/12/13 Ed:4) Fire and Leakage Test of Grease Duct Access Doors and Fittings
 - UL 710 (Issued: 2012/09/13 Ed: 6 Rev: 2013/11/05) Exhaust Hoods for Commercial Cooking Equipment
 - ULC S646 (Issued: 2010/07/01 Ed:3) Standard for Exhaust Hoods and Related Controls for Commercial and Institutional Kitchens.



Dimensions	Description	Constraints
A	Hood Collar Section Length / Duct Section Length	
B	Hood Collar Section Width / Duct Section Width	
C	Minimum Clearance	$C \geq B / 2$ and $C \geq 4''$ (100 mm)
D	Hood Collar /Duct Cut-Out Diameter	$7/8''$ (22 mm)
E	Hood Collar Minimum Height	$E \geq B$

Hood collar application

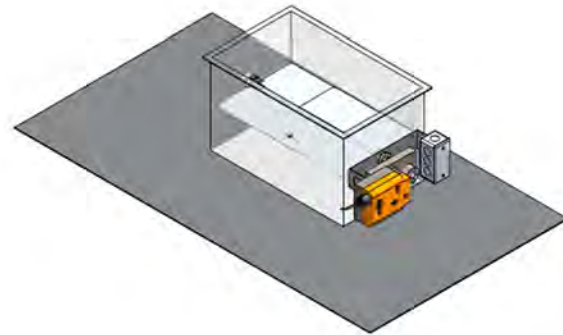
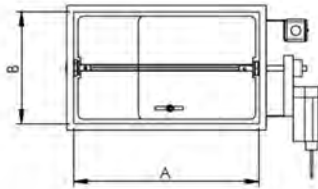
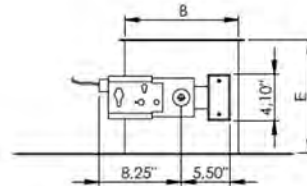
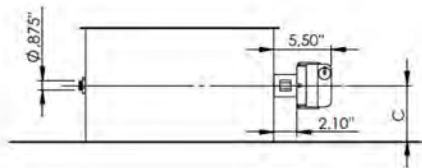

Exhaust duct application

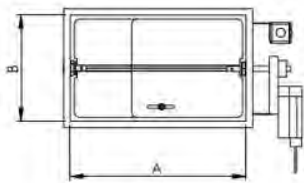

Modulating Damper Location

- Must be located within 18" (0.45 m) of a hood collar or an access door.
- Must be mounted on the vertical sides of a hood collar or of an exhaust duct.
- Must be accessible for maintenance purposes.
- Not intended as a fire suppression damper.
- Different restrictions may apply depending on national, state and local codes and regulations.
- Refer to the installation guide for further information.

Maintenance

- Verify actuator/damper rotation & fail-safe action yearly.

PATENT PENDING

V4MD-R, V4MD-C series
ECOAZUR® Modulating Damper Blade

MODULATING DAMPERS

Functional Description

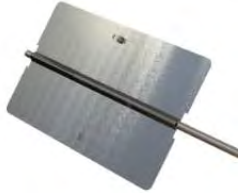

V4MD-R series



V4MD-C series

The V4MD-R and V4MD-C damper blade assemblies are designed to modulate airflow in commercial kitchen Type 1 and Type 2 hood applications.

Their retractable design offers a safe and simple installation process, in new and retrofit applications. **No welding is required.**

The V4MD-R and V4MD-C damper blades are intended to be used as part of the ECOAZUR® DCKV control system, in conjunction with the V4MD series actuators.

Model Prefix	Blade Format	Duct section length (dimension parallel to shaft)	Duct section width (dimension perp. to shaft)
V4MD-R12	Rect. "BLR1"	6" – 12" (152 – 305 mm)	6 – 12" (152 mm – 305 mm)
V4MD-R18	Rect. "BLR2"	13" – 18" (330 – 457 mm)	6 – 16" (152 mm – 406 mm)
V4MD-R24	Rect. "BLR2"	19" – 24" (483 – 610 mm)	6 – 16" (152 mm – 406 mm)
V4MD-R30	Rect. "BLR3"	25" – 30" (635 – 762 mm)	6 – 16" (152 mm – 406 mm)
V4MD-R36	Rect. "BLR3"	31" – 36" (787 – 914 mm)	6 – 16" (152 mm – 406 mm)
V4MD-C18	Round "BLC1"	8" – 18" (203 – 457 mm) diameter	

Exact duct or collar external dimensions must be confirmed when ordering V4MD-Rxx or V4MD-Cxx part numbers. See "Ordering" section.

Specifications

	BLR1	BLR2	BLR3	BLC1
Blade Format	BLR1	BLR2	BLR3	BLC1
Blade & Shaft Material	STST	STST	STST	STST
Blade Thickness	18 GA (1.3mm)	16 GA (1.6 mm)	16 GA (1.6mm)	16 GA (1.6mm)
Shaft Diameter	0.5" (12.7 mm)	0.5" (12.7 mm)	0.5" (12.7 mm)	0.5" (12.7 mm)
Master Shaft length	6" (152 mm)	6" (152 mm)	6" (152 mm)	6" (152 mm)
Weight	Size dependant	Size dependant	Size dependant	Size dependant

Agency Listing

Listed as part of the ECOAZUR® DCKV Control System:



- Conforms to ANSI/UL Standard 2017, Safety General-Purpose Signaling Devices and Systems.
- Certified to CAN/CSA Standard C22.2 No. 205, Signal Equipment
- Additionally, evaluated and found to comply with:
 - UL 1978 Clause 19 (Issued 2010/12/13 Ed:4) Fire and Leakage Test of Grease Duct Access Doors and Fittings
 - UL 710 (Issued: 2012/09/13 Ed: 6 Rev: 2013/11/05) Exhaust Hoods for Commercial Cooking Equipment
 - ULC S646 (Issued: 2010/07/01 Ed:3) Standard for Exhaust Hoods and Related Controls for Commercial and Institutional Kitchens.

Dimensions (inches)

V4MD-R series

- W** Hood collar width or duct section width
(dimension perpendicular to the damper shaft)

- L** Hood collar length or duct section length
(dimension parallel to the damper shaft)

- W – 0.75"** Damper width or duct section width
(dimension perpendicular to the damper shaft)
rounded to the nearest quarter of an inch

- L rounded to the nearest inch** Damper length (adjustable +/- 1.9" (48 mm))
(dimension parallel to the damper shaft)

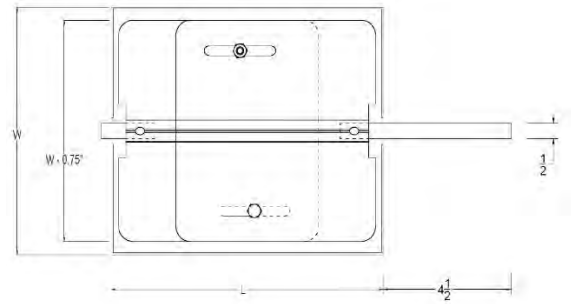

Dimensions (inches)

V4MD-C series

- D** Hood collar diameter or duct section diameter

- D – 0.75"** Damper blade diameter
rounded to the nearest quarter of an inch

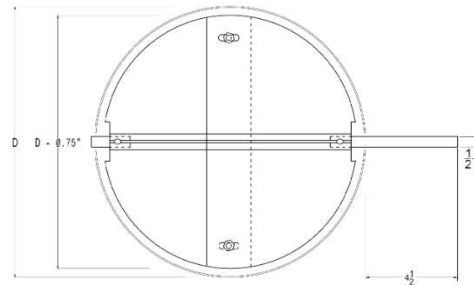

Ordering

V4MD-R**xx-yy-zz.zz**

xx: Prefix 12, 18, 24, 30 or 36 (size category)
yy: L (inches), *round to the nearest inch*
zz.zz: W – 0.75" (inches), *rounded to the nearest quarter of an inch*

Ordering example

Order a **V4MD-R18-13-9.25** for a 13" x 10" hood collar or duct section, where 13" is the dimension parallel to the shaft (size category R18).

V4MD-C**xx-zz.zz**

xx: Prefix 18 (size category)
zz.zz: D – 0.75" (inches), *round to the nearest quarter of an inch*

Ordering example

Order a **V4MD-C18-11.25** for a 12" round hood collar or duct section.

V4MD-PT5

ECOAZUR® Exhaust Duct Pressure Transmitter

PRESSURE CONTROL

Functional Description



The V4MD-PT series exhaust duct pressure transmitter is designed to supervise and/or control static pressure in a commercial kitchen grease duct application (Type 1 and Type 2 hoods).

The V4MD-PT is intended to be used as part of the ECOAZUR® DCKV control system, in new or retrofit applications.

Specifications

Power Supply	24 VAC +/-10%, 50/60Hz, 12-36 VDC, Class 2 power source
Power Consumption	< 0.2 VA
Electrical Connections	3 wire, 18 GA plenum rated cable, ½" conduit connector
Modulation	0-10V
Range	V4MD-PT5 0 - 5" WC (0 – 1244 Pa)
Operating Temperature	32 to 167 deg F (0 to 75 deg C)
Terminal Block Torque	4.5 to 5.3 in-lbs (0.5 to 0.6 Nm)
Grease Duct Fitting	0.25" (6.35 mm) Compression Seal
Duct Pressure Port	STST Tube, 0.25" (6.4 mm) OD, 0.18" (4.6 mm) ID
Ambient Pressure Port	0.25" (6.35 mm) OD, 0.17" (4.3 mm) ID
Weight	5.4 lb (2.5 kg)

Agency Listing

- The duct penetration seal is listed with Underwriters Laboratories under the classification "Hood and Duct Accessories".

Dimensions Description

¾"	Duct Cut-Out Diameter
----	-----------------------

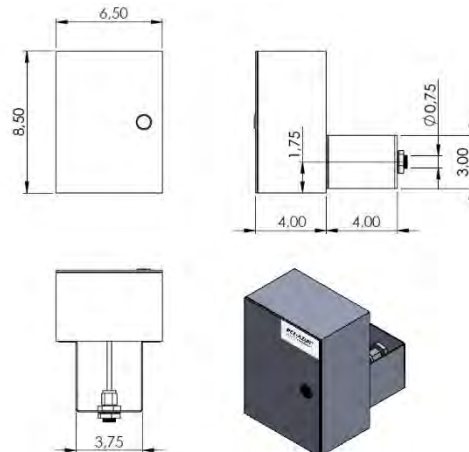

Transmitter Location

- Must be mounted less than 18" (0.45 m) away from an access door.
 - Must be mounted on the vertical sides of an exhaust duct.
 - Must be mounted between the exhaust fan and the modulating dampers (upstream of the fan and downstream of all modulating dampers).
 - Locate near the hoods.
 - Must be accessible for maintenance purposes.
 - Refer to the installation guide for further information.
-

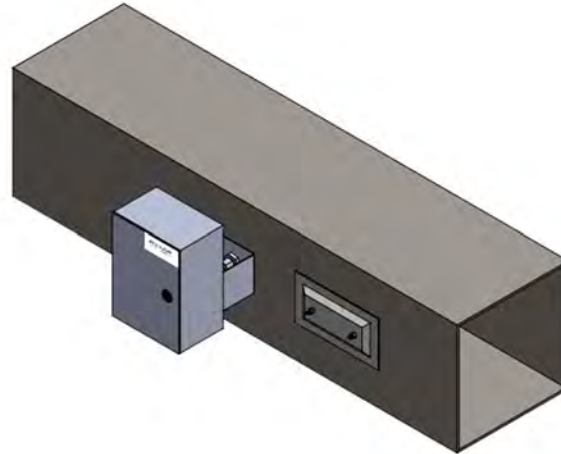

Maintenance

- Clean pressure port yearly. Refer to the User's Manual.
-